



OR Series-Oil Cooler



OR 60L

- Size
- 60L
- 100L
- 150L
- 250L
- 350L
- 600L
- 800L
- 1000L

Series No.

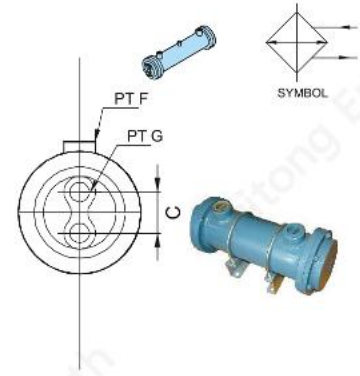
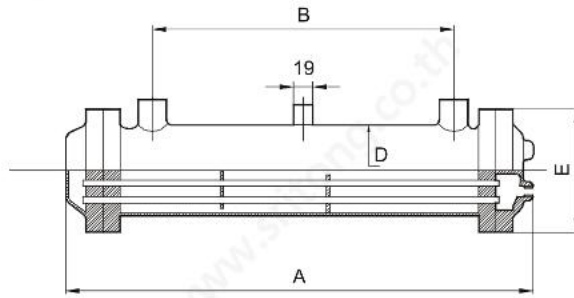

Series	A	B	C	D	E	F	G	Tube (pcs)	Heat Transfer Area (m ²)	Oil Flow (l/min)	Water Flow (l/min)	Weight (kg)
OR-60	465	295	40	89.1	120	¾	¾	22	0.24	60	60	8
OR-100	540	370	55	114.3	140	¾	¾	26	0.35	100	100	12
OR-150	580	375	65	139.8	170	1 ¼	¾	42	0.60	150	150	15
OR-250	800	600	65	139.8	170	1 ¼	¾	58	1.20	250	150	22
OR-350	1205	1000	65	139.8	170	1 ¼	¾	58	1.90	350	150	30
OR-600	1225	970	85	165.2	196	2	1 ½	58	1.90	600	200	40
OR-800	1725	1470	85	165.2	196	2	1 ½	58	2.80	800	200	50
OR-1000	2140	1890	85	165.2	196	2	1 ½	58	3.50	1000	200	60
OR-1200	2520	2270	85	165.2	196	2	1 ½	58	4.20	1200	200	70