

Cam Operated Directional Valve

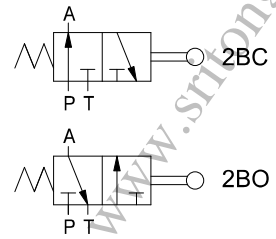

閥類型符號 SYMBOL
DCG-02-※-10-※



規格說明 SPECIFICATION

型式 MODEL	最高使用壓力 MAX. OPERATING PRESSURE kgf/cm ²	最大容許背壓 MAX. BACK PRESSURE kgf/cm ²	最大流量 MAX. FLOW L/min	重量 WEIGHT kg
DCG-02-※-10-※	210	70	30	1.4

型號說明 HOW TO ORDER

DC G - 02 - 2BC - 10 - R

附屬品 ATTACHMENT

型式 MODEL	安裝螺絲 SOC HOL CAP SCREW	安裝扭矩 MOUNTING TORQUE N·m
DCG-02-※-10-※	M5 X 45L.....4pcs	8~9

輪轉方向 RELLER POSITION (O型環固定面為基準)
R : 左側 LEFT S : 右側 RIGHT
Y : 上側 UPSIDE

設計編號 DESIGN NUMBER

閥型式 VALVE TYPE

2BC : 常態P通A (壓桿在B側) 切換A通T
USED TO FROM P TUNG A,
(PRESS POLE IN B SIDE) ALT A TUNG T.

2BO : 常態A通T (壓桿在B側) 切換P通A
USED TO FROM A TUNG T,
(PRESS POLE IN B SIDE) ALT P TUNG A.

閥規格 VALVE SIZE

02 : 20 L/min

安裝型式 MOUNTING

G : 板式安裝 SUB-PLATE MOUNTING

系列編號 SERIES NUMBER

單位 UNIT : mm

安裝尺寸

INSTALLATION DIMENSIONS

DCG-02-※-10

通用底板尺寸
 APPLICATIVE
 SUB-PLATE DIMENSIONS
MC - 02 - 1
 (詳見 E01-09 Page E01-09)

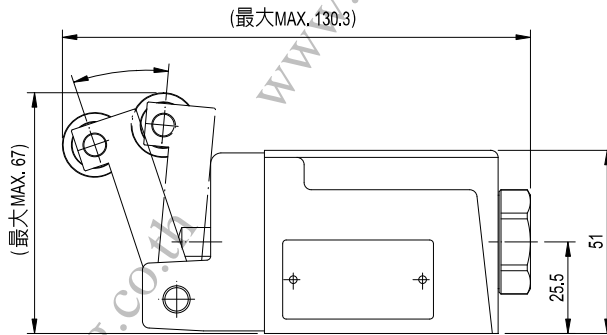
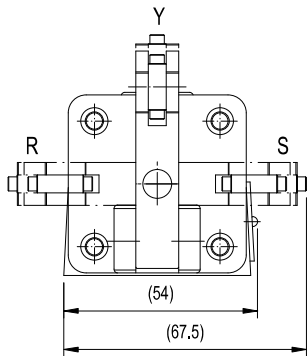
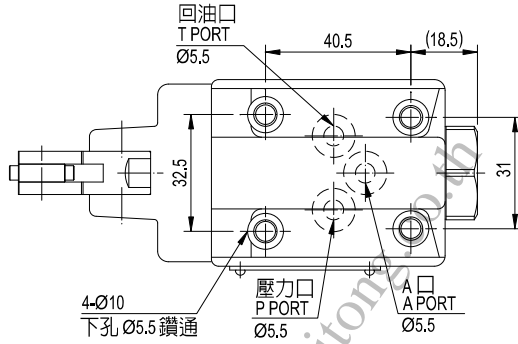

www.sritong.co.th



閥類型符號 SYMBOL
DCG-02-※-20-※

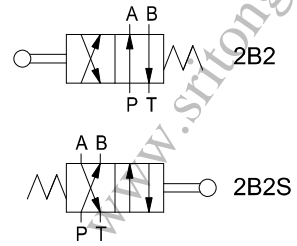

規格說明 SPECIFICATION

型式 MODEL	最高使用壓力 MAX. OPERATING PRESSURE kgf/cm ²	最大容許背壓 MAX. BACK PRESSURE kgf/cm ²	最大流量 MAX. FLOW L/min	重量 WEIGHT kg
DCG-02-※-20-※	210	70	30	1.4

型號說明 HOW TO ORDER

DC G - 02 - 2B2 - 20 - R

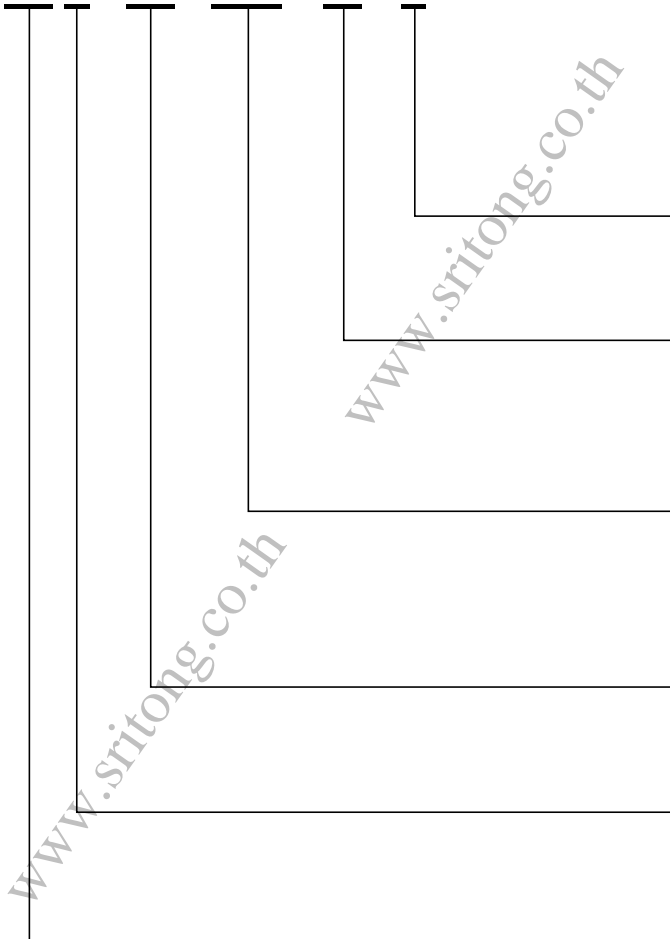

附屬品 ATTACHMENT

型式 MODEL	安裝螺絲 SOC HOL CAP SCREW	安裝扭矩 MOUNTING TORQUE N·m
DCG-02-※-20-※	M5 X 50L.....4pcs	8~9

輪轉方向 RELER POSITION (O型環固定面為基準)
R : 左側 LEFT S : 右側 RIGHT
Y : 上側 UPSIDE

設計編號 DESIGN NUMBER

閥型式 VALVE TYPE
2B2 : 常態P通A, B通T (壓桿在A側) 切換P通B, A通T
 USED TO FROM P TUNG A, B TUNG T
 (PRESS POLE IN A SIDE) ALT P TUNG B, A TUNG T.
2B2S : 常態P通B, A通T (壓桿在B側) 切換P通A, B通T
 USED TO FROM P TUNG B, A TUNG T
 (PRESS POLE IN B SIDE) ALT P TUNG A, B TUNG T.

閥規格 VALVE SIZE
02 : 20 L/min

安裝型式 MOUNTING
G : 板式安裝 SUB-PLATE MOUNTING

系列編號 SERIES NUMBER

單位 UNIT : mm

安裝尺寸 INSTALLATION DIMENSIONS

DCG-02-2B2S-20

通用底板尺寸
 APPLICATIVE
 SUB-PLATE DIMENSIONS
MC - 02 - 1
 (詳見 E01-09 Page E01-09)

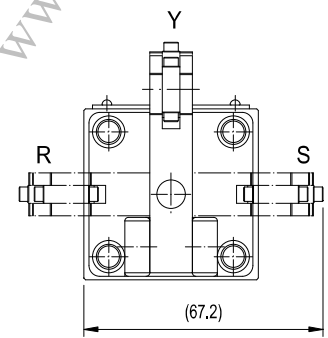
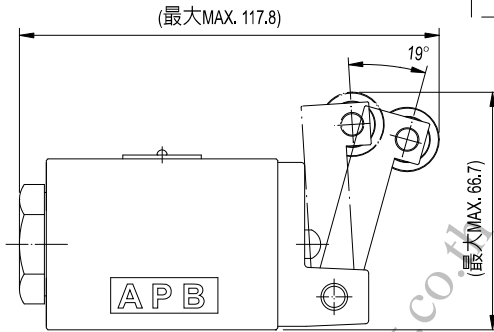
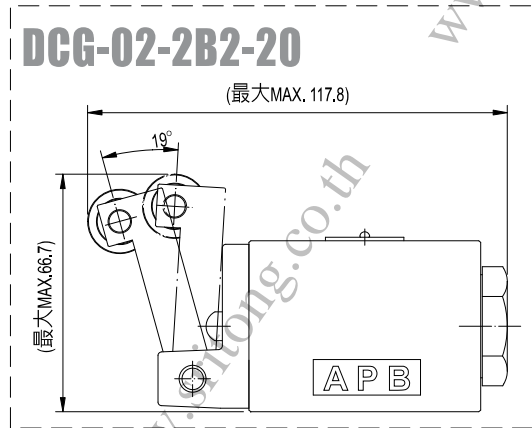
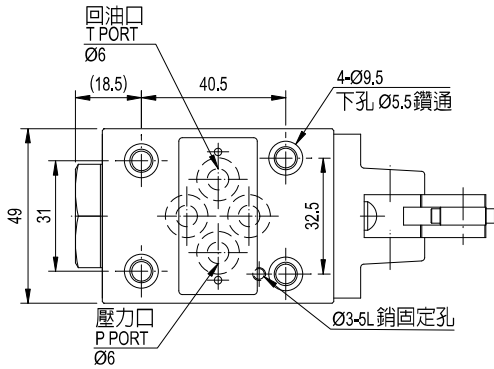

測試條件 PERFORMANCE CURVES

測試油黏度 TEST FLUID VISCOSITY : 35cSt

測試油溫度 TEST TEMPERATURE : 50°C

● DCG-02-2B※-※

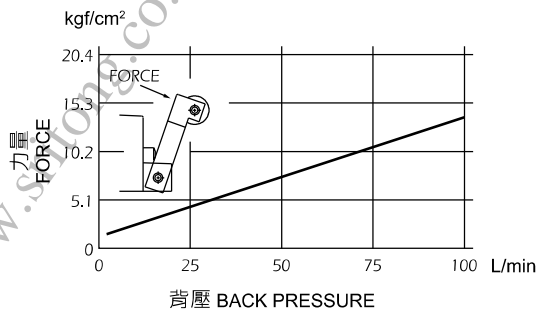

● DCG-02-2B※-※

